

- The launch of the new WIAT web-site, with special spare part offers for our Customers.
- Mitsubishi launched their Regional Jet MRJ and WIAT cooperation during the development phase.
- WIAT presents the FAST PRIMO seat for the Antonov 148 Regional Jet.
- The FAST PRIMO passenger seat on the Hamburg Interior Expo 2008.
- WIAT in the race to become the European Spares Center for the Eclipse 500 revolutionary Business Jet.
- Bearings supply, a new service from WIAT to the market.
- WIAT forward exchange program on the Fokker 50 & 100 Hydraulic Pumps.

Dear Industry Colleagues,

We are pleased to introduce herewith our 3rd Newsletter to you as our Customer.

Whereas in Newsletter 1 & 2 we highlighted primarily technical issues of the Fokker 50, 70 & 100 we like to draw your attention to other issues this time, especially items we consider as developments within our Company.

We hope that they are interesting to you, and we are looking forward to broaden our relationship for the years to come. Have a nice reading.

The launch of the redesigned and improved WIAT BV web-site www.wiat.nl

The continuous growth of our Company made it necessary to restyle and improve our web-site.

The idea behind it is also to improve it in such a way that it becomes a better tool to communicate with our Customers.

Monthly update of developments as well as frequently refreshed overview of our specials offers with interesting discounts can further help you to find the right parts at the best price.

Next to our core business as spare parts provider, you may also find further details on the consultancy activities we offer to the market. On a regular basis we can support you with;

- Pre-Aircraft purchasing phase.
- Aircraft purchasing phase.
- Aircraft bridging to start operation within the Airline.
- Technical Auditing during the Lease Term.
- Re-delivery preparation & Re-delivery.
- Aircraft Dismantling.
- Purchasing & Logistics.
- Engineering, Technical Administration and Maintenance Reserve policy advises.
- Quality Management.
- Base- and Line & Heavy Maintenance.
- Project Management on Interior Refurbishments Programs & new Pass Seat introduction.
- Project Management launching a PART 145 approved organization.
- Project Management Partners and Subcontracting at a new Aircraft Development.

When you may have questions or want to have a further detailed description or quote, call us or e-mail to info@wiat.nl



Mitsubishi launched their Regional Jet (MRJ).

Mitsubishi has launched the Mitsubishi Regional Jet (MRJ) programme on April 1st, is establishing a new company to spearhead it and has established a new wholly-owned subsidiary in Nagoya, tentatively called Mitsubishi Aircraft that will oversee the programme. The MRJ90 is a 90-seat regional jet and MHI also plans to build the 70-seat MRJ70.

In support of this development WIAT introduced the FAST PRIMO Passenger seat for this Aircraft at the Hamburg Interior Expo, simply because it is designed especially for Regional Aircraft and certified on the Fokker 50 and Fokker 100, consequently the MRJ70 & 90 would be a logical decision as well.

The coming months ADSE (a Dutch Consultancy & Engineering Company) will support Mitsubishi with the selection of the 1st tier suppliers, and we are looking forward to work with our former Fokker colleagues of ADSE as well as with Mitsubishi.

WIAT presents the FAST PRIMO seat for the Antonov 148 Regional Jet.

The certification of the Antonov 148 has been completed now, as well as the portfolio of sales have reached over 150 Aircraft in backlog, the production facility is now under preparation to start production.

For this aircraft the same arguments as to the MRJ 70 & 90 applies, the FAST PRIMO seat is perfectly suited for this 2 and 3 abreast regional jet. The complete picture of the FAST PRIMO seat is now as follows;

Certified Applications per 2008

Antonov 140
Fokker 50 & 100
Dassault Falcon
Zeppelin NT

Suited for

Embraer 170 / 175 / 190 program
Mitsubishi Regional Jet (MRJ)
CRJ 100 / CRJ 200
Antonov 148



The Hamburg Interior Expo and the booth of FAST.

With over 12.000 visitors the Hamburg Interior Expo became a great success again. Also, our FAST booth was a popular place to be and we welcomed a lot of our Customers and potential Customers during the 3 days we presented the PRIMO seat.

Several interesting discussions with Aircraft operators as well as Aircraft Manufacturers made it the place to be.

FAST reached an impressive milestone early 2008 being the certification of the PRIMO seat on the Fokker 100.

With oil crude prices sky high the unbeatable FAST PRIMO seat design will save you cost on spare parts and inventory and is as such a contributor to keep your Airline profitable.

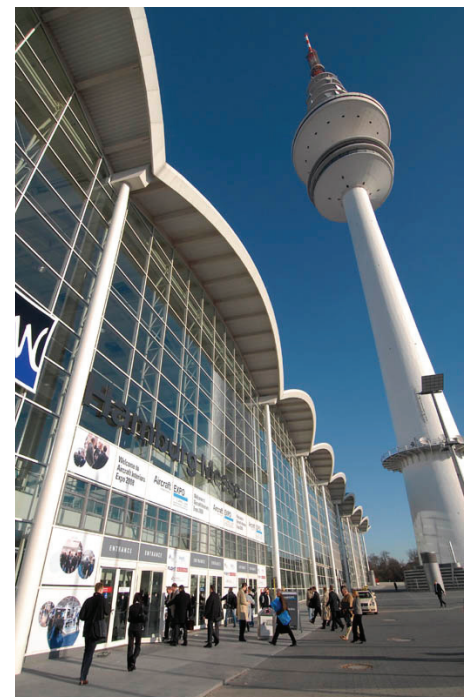

Certainly most of you were busy with an overloaded agenda and not in the position to visit Hamburg at all or our booth in particular. Therefore when you want to know more about the PRIMO seat on the Fokker 50 & 100 please send us an e-mail and we will definitely follow this up.

WIAT in the race to become the European Spares Center for the Eclipse 500 VLJ revolutionary Business Jet.

Eclipse Aviation is the world's leading Very Light Jet (VLJ) manufacturer, producing innovative, affordable jets that are revolutionizing air transportation. The company created the VLJ category with the design, certification and delivery of the Eclipse 500 - the industry's first VLJ. Eclipse applies advanced technologies, manufacturing processes and business practices to create high-performance aircraft that cost a fraction of other jets, and provide the lowest cost of jet ownership ever achieved. The backlog order book is very impressive with over 3000 units sold already, over 150 units in service and a production rate moving up to 2.5 aircraft per day.

During 2007 ETIRC headed by the Dutch entrepreneur Mr. Roel Pieper invested over 1 million USD in Eclipse Aviation as well as the purchase of 160 Eclipse VLJ Aircraft, aimed to be positioned in Europe and Eastern Europe to serve as Air Taxi. EASA certification of the VLJ will be accomplished in the 4th quarter of 2008, with deliveries to Europe in a couple of months. In order to support this product with spare parts, WIAT has been approached by ETIRC Aviation to set up the Spare parts facility in the Netherlands.

Logically this new spare parts market will be added to the present WIAT spare parts supply business toward the Fokker operators worldwide and further broaden our activities.

Bearings supply, a new service from WIAT to the marketplace

As from the second quarter 2008 WIAT is offering their support on the supply of Bearings as well.

Our primary focus is on the Airbus Boeing and Fokker Aircraft product, driven by our excellent relationship for already one decade with one of the largest Bearing Distributors in the world.

To lower the MRO cost of your aircraft we explore our efforts to initiate PMA incentives, serving reliable alternatives with savings up to 40% compared to the traditional OEM price levels.

Next to MS-standards, of course we support the FoN product to the maximum extent including the approved OEM alternatives.

We would be pleased to receive your quote request of individual part numbers, or taking care of the annual stocking of your Bearing demand through the MRO year. For further information please submit your enquiries via e-mail to info@wiat.nl



WIAT exchange program on the Fokker 50 & 100 Hydraulic Pumps.

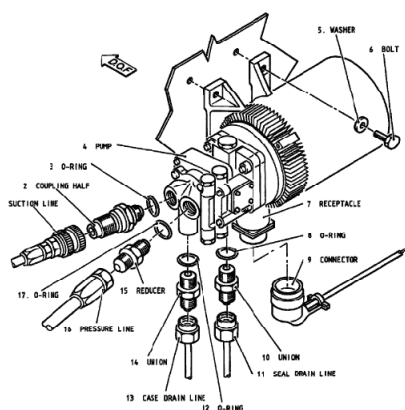

After the introduction of our exchange program on the Fokker 50 starter motor, we can also offer you now an identical solution on the Fokker 50 & 100 Hydraulic Pumps as well.

When you need a replacement unit for p/n 42011 or 4201301, e-mail us and you will get a fully overhauled unit as temporary replacement. After shipment of the unit to be repaired we will return the repaired or overhauled unit within 5 weeks, with a warranty of 1 year on repair and 2 years on the overhaul.

When you prefer to step into a contract or want to know more about price information, contact us on info@wiat.nl

When you have demands for the Fokker 50, 70 & 100 on:

Tension Regulators, Starter Motors, Servo Mounts and Servo Motors, Bearings, Hydraulic Pumps, Fans, Seattracks, Floorbeams, Flight Control cables, Brackets, Actuators, Standard hardware like, Connectors, Bolts, Nuts, Screws, Washers, Valve's, Rivets, Wiring, we have them all at stock in a NEW SURPLUS condition, with cert's.

Call or e-mails us at
AOG desk available, phone

info@wiat.nl
#31 (0)23 531 6039).

WIAT BV

- ✓ Aircraft Lease Management
 - ✓ Aerospace Consultants on your Aircraft fleet in operation
 - ✓ Spare parts provider Boeing – Airbus – Saab – ATR and Fokker Aircraft.
- ✓ Forward Exchanges on Starter Motors and Hydraulic Pumps
- ✓ Warehouse 1.500 square meters at the Airport of Lelystad (30 min. to Schiphol Airport).

- ✓ The Marketing & Sales Organization for
 - Aeroworks Composites for all Fokker Aircraft Interior repair & refurbishment and
 - FAST Fokker 50 & 100 Aircraft Passenger Seat Manufacturers.

WIAT Warehouse at Lelystad Airport



How to reach us:

WIAT B.V.
 Berkenrodestraat 20
 2012 LB Haarlem
 The Netherlands

Phone: including AOG desk

#31(0) 23 531 6039

Fax:

#31 (0)23 534 3142

Request for Quotes to be forwarded to

info@wiat.nl

Further information on our company can be found on www.wiat.nl

Managing Director:

Mr. Louis Wijers

Director Marketing & Technical Affairs:

Mr. Ton Ledegang